

NOTES: UNLESS OTHERWISE SPECIFIED
 1. COCKPIT DESIGN IS GENERIC AND NOT AIRCRAFT SPECIFIC
 2. -X REFERS TO ALL 107P-049 & -050 SUB MODELS

SEE SHEET 4 of 5

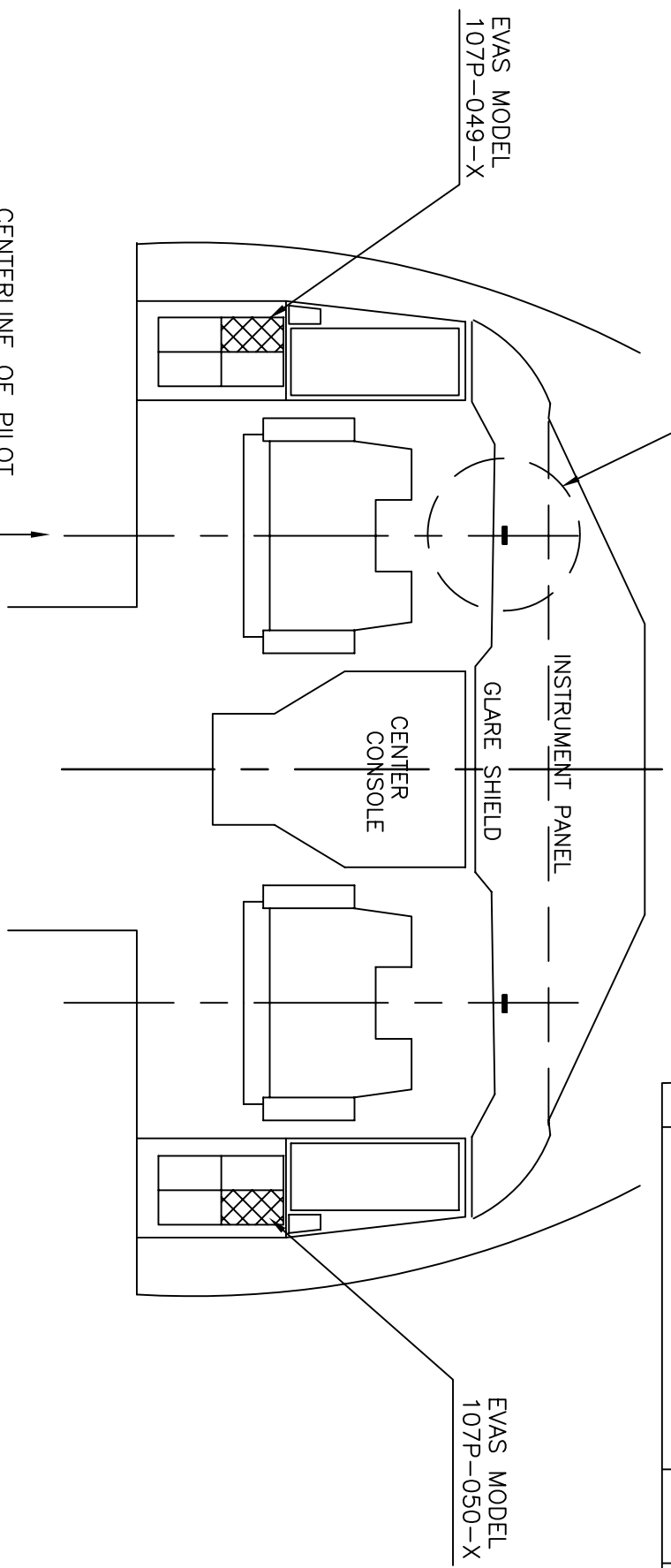

REV	DESCRIPTION	DATE	APPROVAL
A	UPDATED 'USED ON' TO INCLUDE V-SP	10/13/04	CBKW
B	UPDATED TITLE BLOCK, 'USED ON', MODEL NUMBERS AND NOTES	01/03/05	CBKW

CENTERLINE OF PILOT SEAT, CONTROL WHEEL AND FLIGHT INSTRUMENTS

ITEM NO.	QTY	FSCM NO.	PART OR IDENTIFYING NO.	NOMENCLATURE OR DESCRIPTION	MATERIAL SPECIFICATION	NOTE
UNLESS OTHERWISE SPECIFIED DIMENSIONS ARE IN INCHES. TOLERANCES ARE FRACTIONS DECIMALS ANGLES						
PARTS LIST						
CONTRACT NO.				VISION SAFE CORPORATION		
MATERIAL				P.O.Box 5011 Kaneohe, HI 96744-5011 (USA)		
FINISH				EVAS MODEL 107P-049-X & -050-X		
APPROVALS				INSTALLATION: VARIOUS GULFSTREAM		
DRAWN HEW				DATE 03/09/04		
CHECKED				SIZE FSCM NO.		
ENG				DIRG NO. 6001		
G.A.				SCALE NONE		
DD NOT SCALE DRAWING				LOCATION 6001001B		
APPLICATION				SHEET 1 of 5		

2

1

A

B

2

1

A

B

SH	REV
2	B

SIZE DVG NO
B 6001

B

A

INSTALLATION OF EVAS 107P-049-X & -050-X

NOTE: BEFORE INSTALLING EVAS, MEASURE THE HORIZONTAL WIDTH OF THE INSTRUMENT CLUSTER TO BE COVERED BY EVAS (SEE SKETCH BELOW).

THIS INSTRUMENT CLUSTER WIDTH MUST NOT EXCEED THE MAXIMUM MEASUREMENT SHOWN. IF THE WIDTH DOES EXCEED THE MEASUREMENT SHOWN, CONTACT VISION SAFE CORP FOR AN APPROPRIATE INFLATABLE VISION UNIT.

2

1

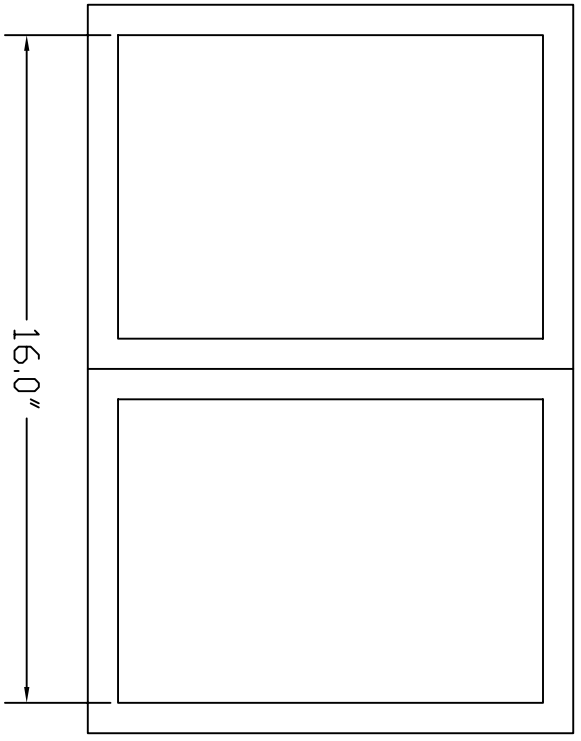

2

1

SIZE	FSCM NO.	DRG NO.	REV.
B		6001	B
SCALE	LOCATION	SHEET 2 of 5	
	6001002B		

A

B

2

1

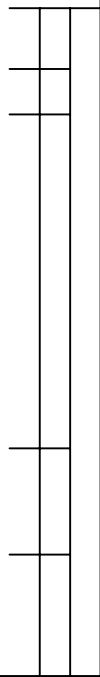

INSTALLATION OF EVAS 107P-049-X & -050-X

EVAS UNIT

1. EVAS MODELS 107P-049-X & -050-X ARE DESIGNED TO FIT THE PILOT FLIGHT DATA CASE WITHOUT ALTERATION. AS THE EVAS IS SELF-CONTAINED, NO ADDITIONAL INSTALLATION IS NEEDED.
2. THE INDICATED LOCATION IS A SUGGESTION. AS EVAS IS LOOSE EQUIPMENT, IT MAY BE STORED IN ANOTHER CONVENIENT LOCATION ACCESSIBLE TO THE PILOT. HOWEVER, PRIOR TO DEPLOYING EVAS, THE UNIT MUST BE ON THE OUTBOARD SIDE OF THE PILOT AND WITHIN ARMS REACH OF THE GLARE SHIELD.

VELCRD

1. CLEAN THE GLARE SHIELD TOP SURFACE FROM THE AFT EDGE FORWARD 5', AND 3' TO EACH SIDE OF THE LONGITUDINAL CENTERLINE THROUGH THE CONTROL WHEEL.
2. CEMENT 1'x5" LOOP VELCRD TO THE GLARE SHIELD. LOCATE THE VELCRD AS SHOWN ON SHEET 4 OF 5. USE DEVCON TWO-TON EPOXY CEMENT.

DOCUMENTATION

1. IN THE OPERATING MANUAL, FLIGHT MANUAL, OR CHECK LIST, AS APPROPRIATE, ADD "DEPLOY EVAS" TO EACH SMOKE EMERGENCY PROCEDURE. USE PERMANENT METHODS COMMENSURATE WITH THE ORIGINAL DOCUMENT, SUCH AS TYPEWRITTEN, PLASTIC-COATED LABEL, ETC.

SIZE	FIG	DRG	NO.	REV.
B			6001	B
SCALE	LOCATION	SHEET 3 OF 5		
	6001003B			

2

1

- NOTE:
1. CLEAN SURFACE
 2. USE DEVCON TWO TON EPOXY

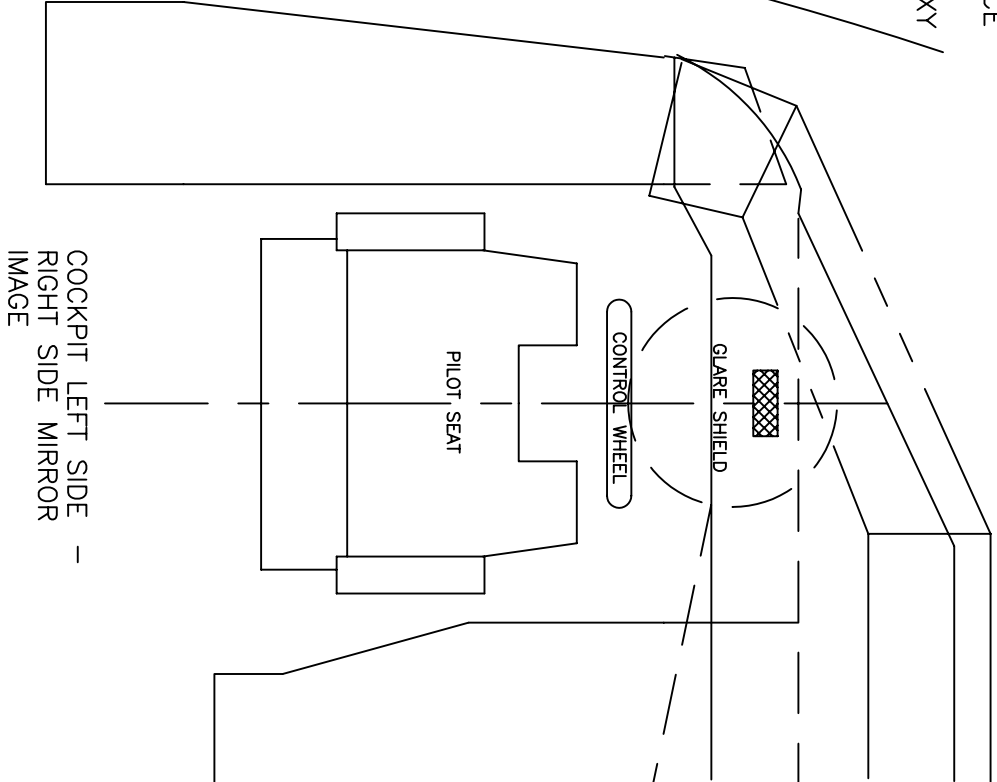

THE INFORMATION CONTAINED HEREIN IS PROPRIETARY AND CONFIDENTIAL TO VISION SAFE CORP., AND SHALL NOT BE DISCLOSED OR COPIED, IN WHOLE OR IN PART WITHOUT THE WRITTEN CONSENT OF VISION SAFE CORP.

IVU VELCRO INSTALLATION

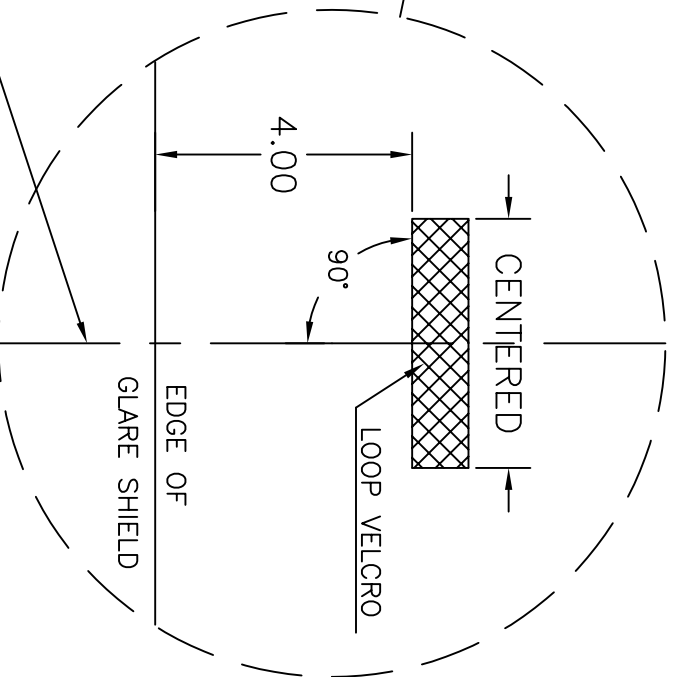

NOTE: CENTERLINE OF PILOT SEAT, CONTROL WHEEL AND PRIMARY FLIGHT INSTRUMENTS.
 NOTE: GLARE SHIELD EDGE ANGLE IS NOT AIRCRAFT SPECIFIC. VELCRO CENTER SHOULD BE AS INDICATED.

2

1

NOTE: IF THE EVAS INSTALLATION IS TO BE MADE IN AN AIRCRAFT WITH AN EXPOSED SUN SHIELD, INSTALL BOTH PIECES OF VELCRO FOR EACH EVAS INSTALLATION. IF THE SUN SHIELD IS NOT INSTALLED OR IS CONTAINED WITHIN THE GLARE SHIELD, INSTALL ONLY THE AFT PIECE OF VELCRO (4" FORWARD AT 90°)

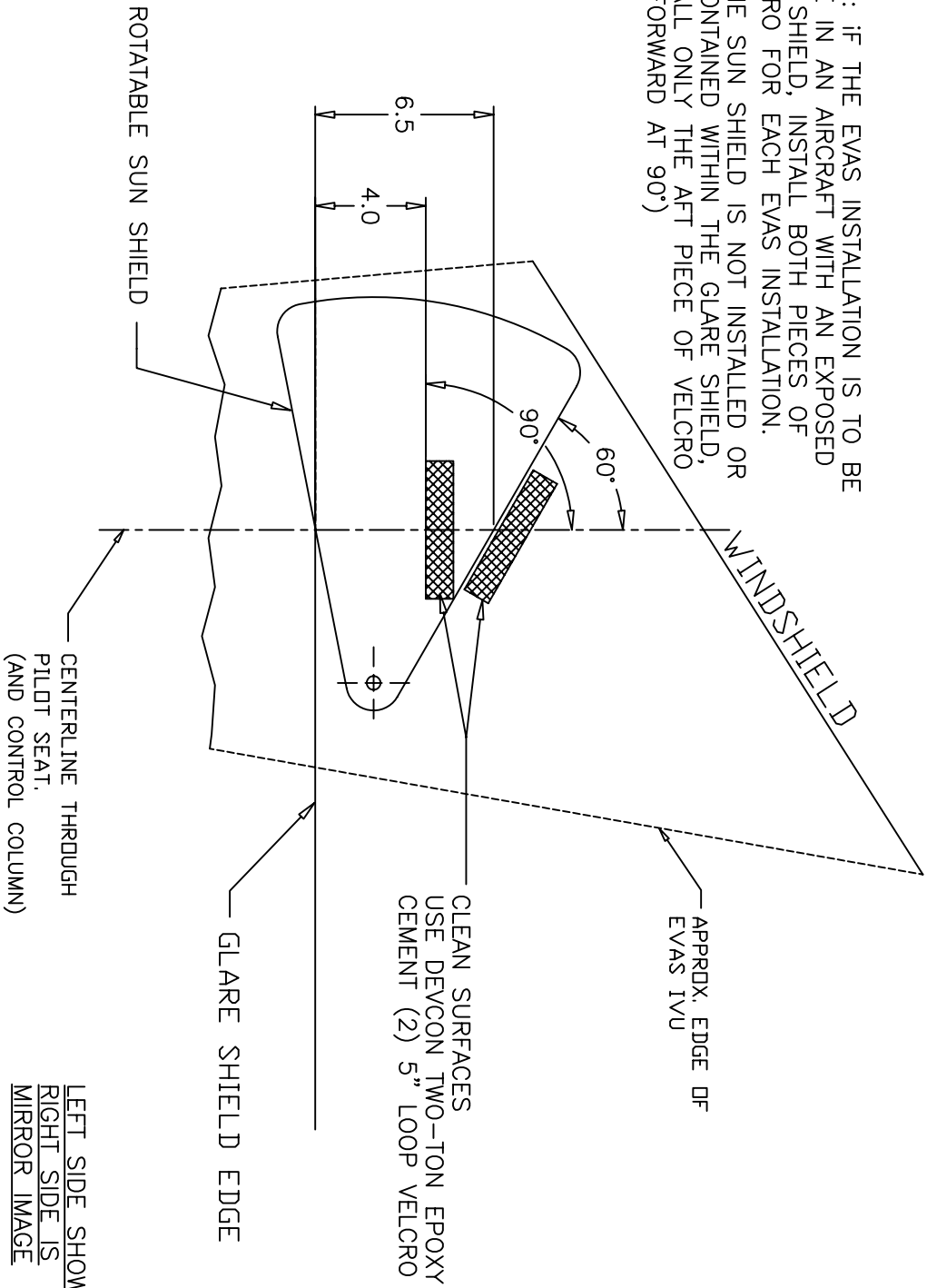

B

A

B

A

2

1

LEFT SIDE SHOWN
RIGHT SIDE IS
MIRROR IMAGE

SIZE	FSCM NO.	DWG NO.	REV.
B		6001	B
SCALE 0.33		LOCATION: 6001005B	SHEET 5 of 5