

2

1

REVISIONS		
REV.	DESCRIPTION	DATE

SEE SHEET 4 of 4

EVAS MODEL
107P-241
DRAWING 6296

EVAS MODEL
107P-242
DRAWING 6296

CENTERLINE OF PILOT SEAT
AND CONTROL WHEEL

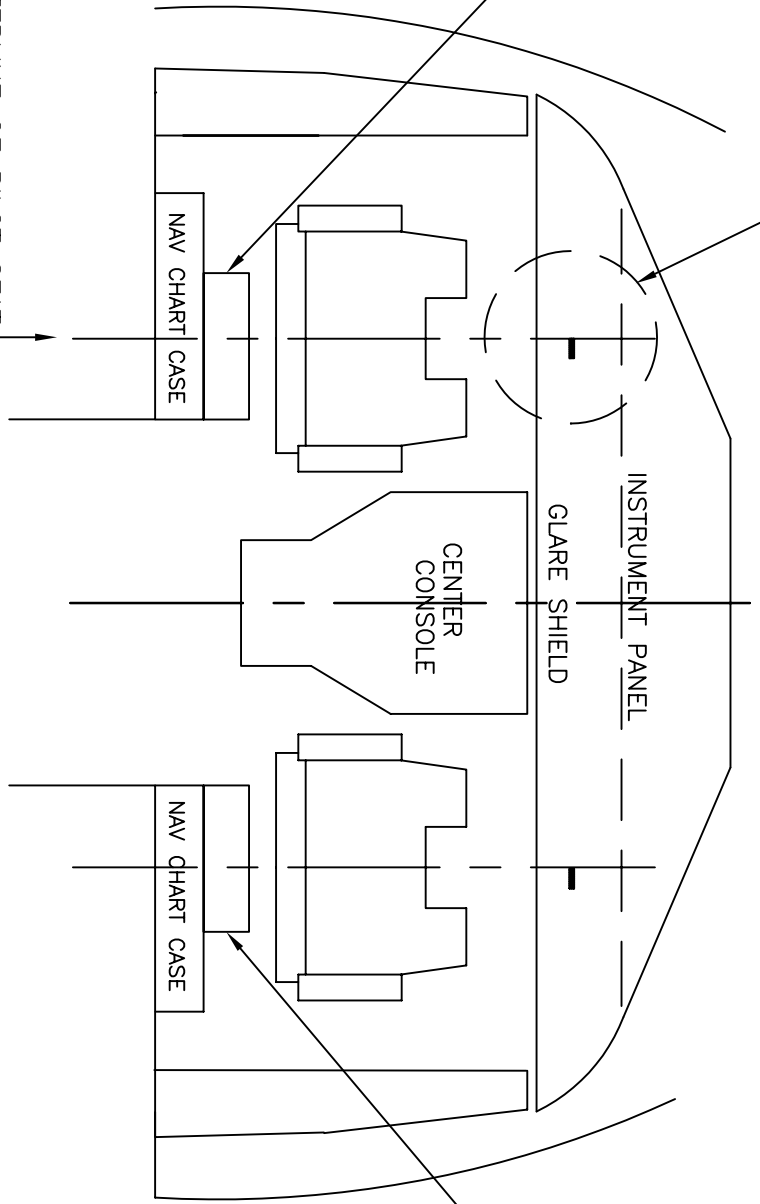

VISIONSAFE	MDL 413
END	CESSNA
NEXT ASSY	USED ON
APPLICATION	

ITEM NO.	QTY	FSCM NO.	PART OR IDENTIFYING NO.	CONTRACT NO.	DATE	APPROVALS	REVISIONS
UNLESS OTHERWISE SPECIFIED DIMENSIONS ARE IN INCHES, TOLERANCES ARE: FRACTIONS DECIMALS ANGLES							
MATERIAL FINISH DO NOT SCALE DRAWING Q.A.							
PARTS LIST				VISION SAFE CORPORATION P.O.Box 5011, Kaneohe, HI 96744-5011 (USA)			
				EVAS MODEL 107P-241 & -242 INSTALLATION: CESSNA 680			
				SCALE NONE LOCATION 6297001 - SHEET 1 of 4			

2

1

2

1

INSTALLATION OF EVAS 107P-241 & -242

NOTE: BEFORE INSTALLING EVAS, MEASURE THE HORIZONTAL WIDTH OF THE INSTRUMENT CLUSTER TO BE COVERED BY EVAS (SEE SKETCH BELOW).

THIS INSTRUMENT CLUSTER WIDTH MUST NOT EXCEED 13" FOR THIS INSTALLATION. IF THE WIDTH EXCEEDS 13", CONTACT VISION SAFE CORP. FOR AN APPROPRIATE INFLATABLE VISION UNIT.

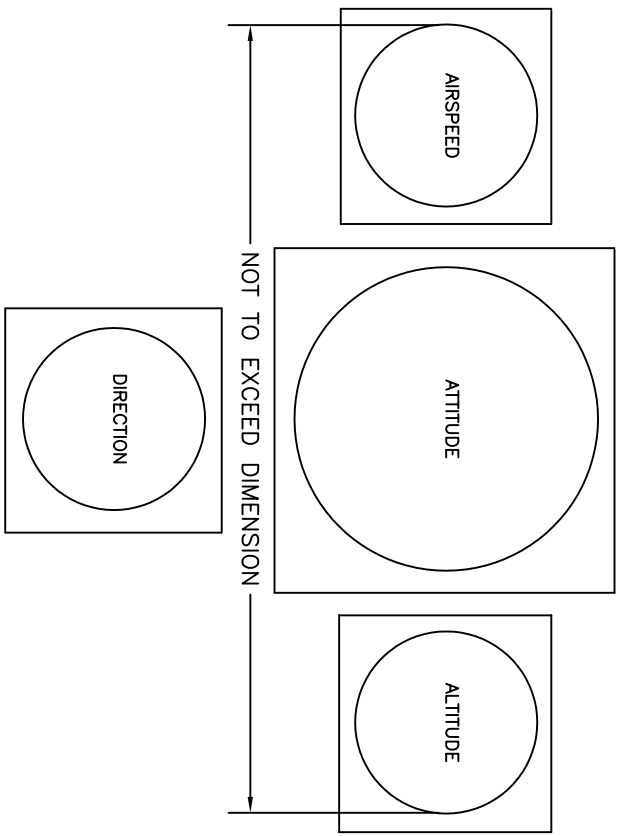

2

1

2

INSTALLATION OF EVAS 107P-241 & -242

NOTE: BEFORE INSTALLING EVAS, MEASURE THE HORIZONTAL WIDTH OF THE INSTRUMENT CLUSTER TO BE COVERED BY EVAS (SEE SKETCH BELOW).

THIS INSTRUMENT CLUSTER WIDTH MUST NOT EXCEED 13" FOR THIS INSTALLATION. IF THE WIDTH EXCEEDS 13", CONTACT VISION SAFE CORP. FOR AN APPROPRIATE INFLATABLE VISION UNIT.

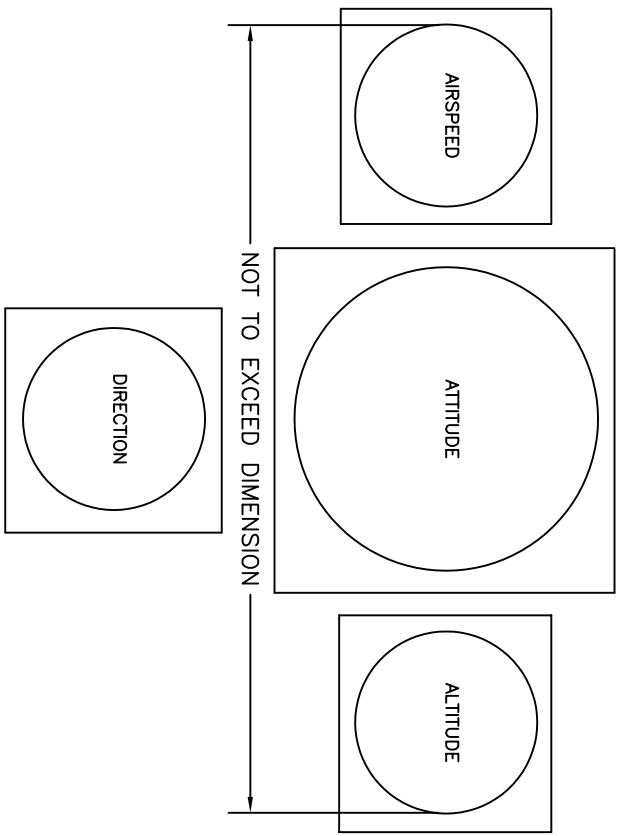

SIZE	FSCM NO.	DRG. NO.	REV.
B		6297	-
SCALE	LOCATION	SHEET	2 of 4
	6297002-		

1

1

2

INSTALLATION OF EVAS 107P-241 & -242

NOTE: BEFORE INSTALLING EVAS, MEASURE THE HORIZONTAL WIDTH OF THE INSTRUMENT CLUSTER TO BE COVERED BY EVAS (SEE SKETCH BELOW).

THIS INSTRUMENT CLUSTER WIDTH MUST NOT EXCEED 13" FOR THIS INSTALLATION. IF THE WIDTH EXCEEDS 13", CONTACT VISION SAFE CORP. FOR AN APPROPRIATE INFLATABLE VISION UNIT.

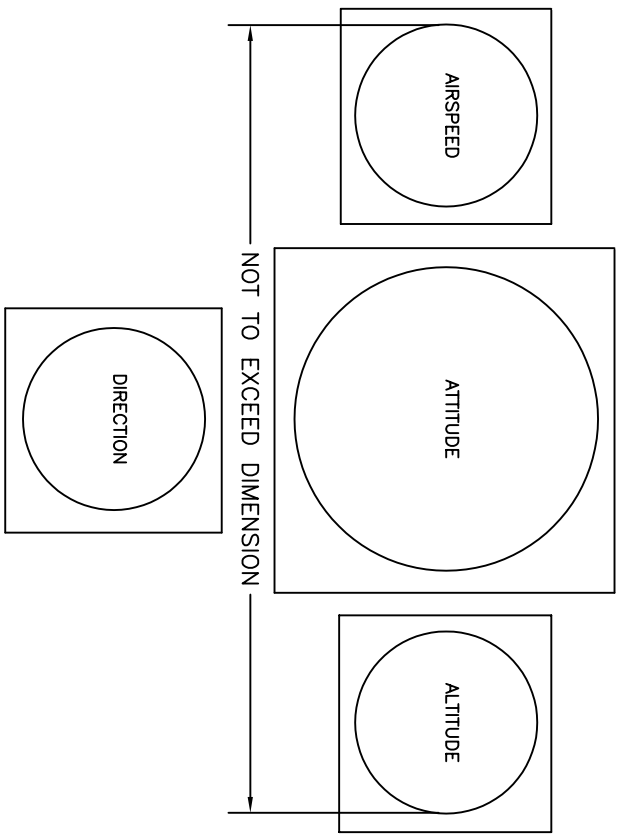

1. CLEAN SURFACE
2. USE DEVCON EPOXY

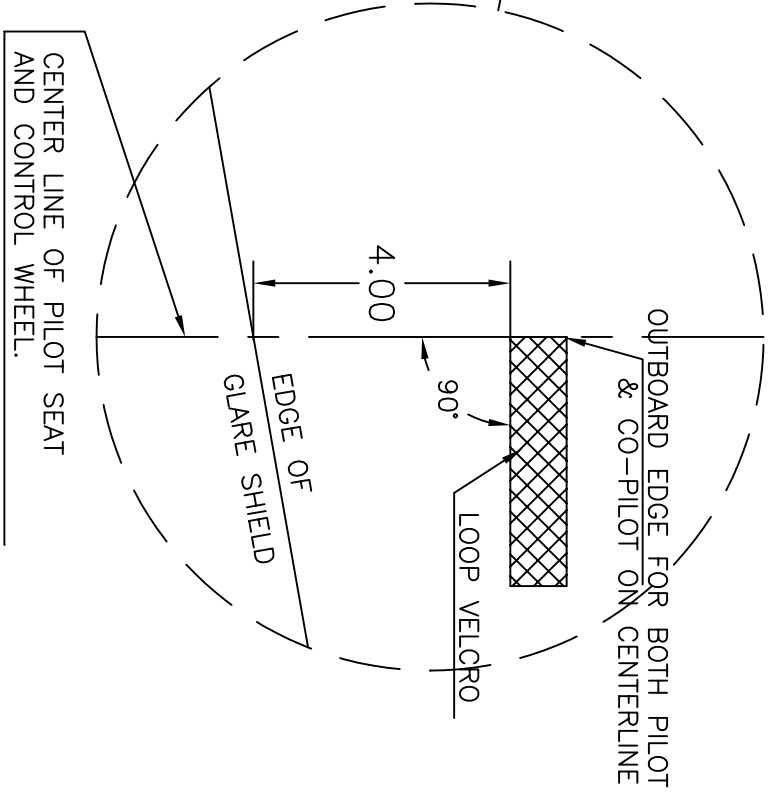
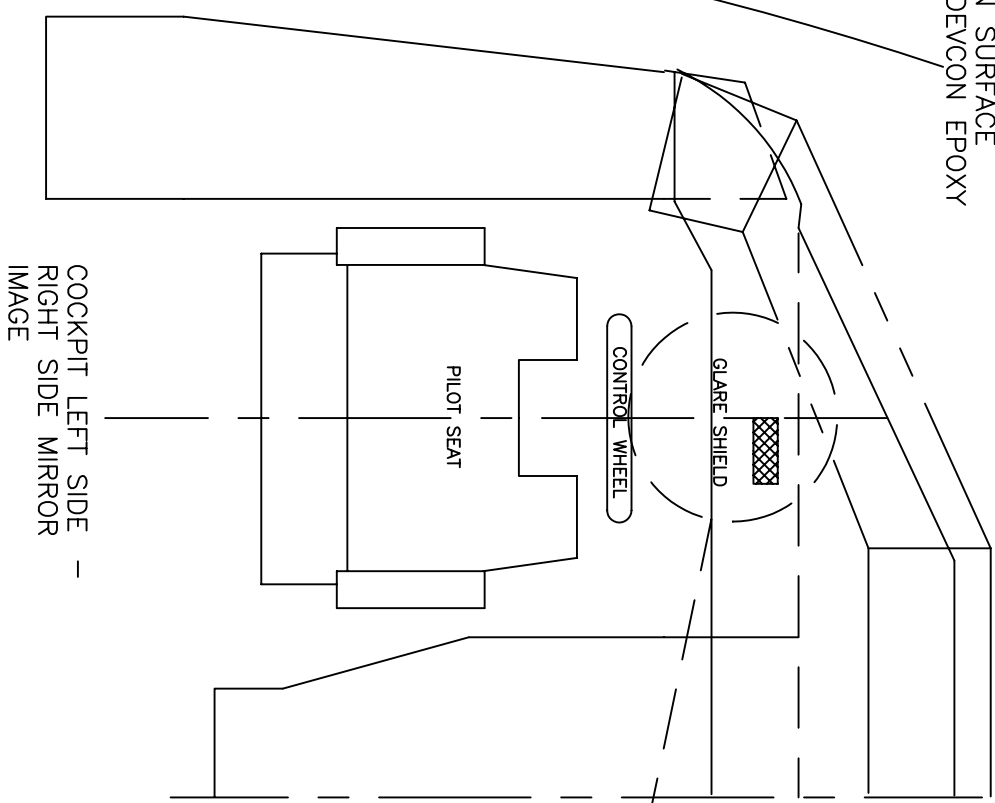

IVU VELCRO INSTALLATION

THE INFORMATION CONTAINED HEREIN IS PROPRIETARY AND CONFIDENTIAL TO VISION SAFE CORP., AND SHALL NOT BE DISCLOSED OR COPIED, IN WHOLE OR IN PART WITHOUT THE WRITTEN CONSENT OF VISION SAFE CORP.