

REV. 1

NOTES: UNLESS OTHERWISE SPECIFIED
 1. COCKPIT DESIGN IS GENERIC AND NOT AIRCRAFT SPECIFIC
 2. -X REFERS TO ALL 107P-049 & -050 SUB MODELS

| REV | DESCRIPTION | DATE | APPROVAL |
|-----|-------------|------|----------|
| | | | |

SEE SHEET 4 of 5

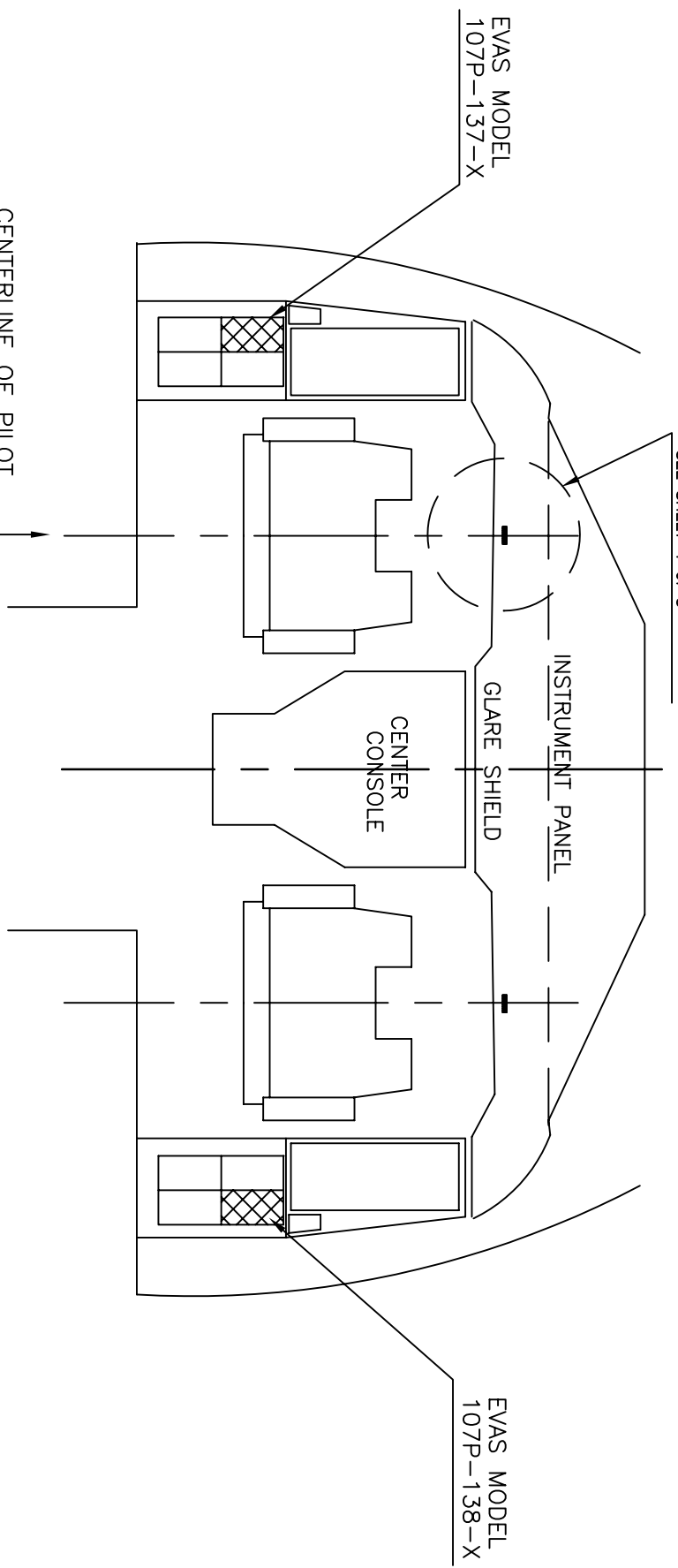

0809
 DWG NO. 6080
 SIZE B

CENTERLINE OF PILOT SEAT, CONTROL WHEEL AND FLIGHT INSTRUMENTS

| ITEM NO. | QTY | FSCM NO. | PART OR IDENTIFYING NO. | NOMENCLATURE OR DESCRIPTION | MATERIAL SPECIFICATION | NOTE |
|---|-----|----------|-------------------------|--|------------------------|------|
| UNLESS OTHERWISE SPECIFIED DIMENSIONS ARE IN INCHES. TOLERANCES ARE FRACTIONS DECIMALS ANGLES | | | | | | |
| PARTS LIST | | | | | | |
| CONTRACT NO. | | | | VISION SAFE CORPORATION P.O.Box 5011 Kaneohe, HI 96744-5011 (USA) | | |
| APPROVALS | | | | DATE | | |
| DRAWN JLH | | | | 03/02/06 | | |
| CHECKED | | | | ENG | | |
| FINISH | | | | SIZE FSCM NO. | | |
| NEXT ASSY USED DN | | | | DIRG. NO. 6080 | | |
| APPLICATION | | | | SCALE NONE | | |
| DD NOT SCALE DRAWING | | | | LOCATION 6080001- | | |
| | | | | SHEET 1 of 4 | | |

A B A B 2 1 2 1

2

1

INSTALLATION OF EVAS 107P-137-X & 107P-138-X

NOTE: BEFORE INSTALLING EVAS, MEASURE THE HORIZONTAL WIDTH OF THE INSTRUMENT CLUSTER TO BE COVERED BY EVAS (SEE SKETCH BELOW).

THIS INSTRUMENT CLUSTER WIDTH MUST NOT EXCEED THE MAXIMUM MEASUREMENT SHOWN. IF THE WIDTH DOES EXCEED THE MEASUREMENT SHOWN, CONTACT VISION SAFE CORP FOR AN APPROPRIATE INFLATABLE VISION UNIT.

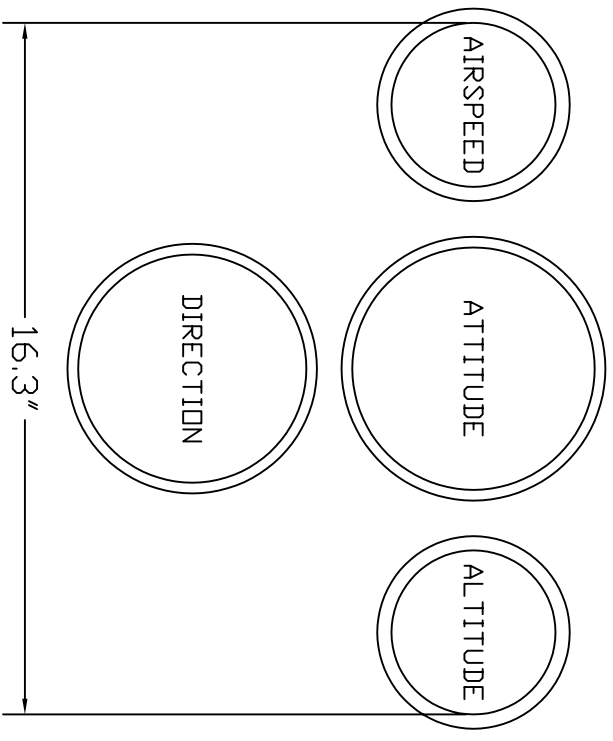

NOTE:
THE INSTRUMENT PRESENTATION SHOWN REPRESENTS FUNCTIONS ONLY, AND IS NOT INTENDED TO BE AN ACCURATE REPRESENTATION OF ANY INSTALLATION. EVAS IS INTENDED TO COVER ONLY THE BASIC FLIGHT INSTRUMENTS.

| | | | | | |
|-------|----------|----------|--------------|------|---|
| SIZE | FSCM NO. | DRG NO. | 6080 | REV. | - |
| B | | | | | |
| SCALE | LOCATION | 6080002- | SHEET 2 of 4 | | |

2

1

A

B

A

B

2

1

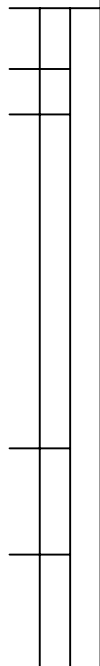

INSTALLATION OF EVAS 107P-137-X & -138-X

EVAS UNIT

1. EVAS MODELS 107P-137-X & -138-X ARE DESIGNED TO FIT THE PILOT FLIGHT DATA CASE WITHOUT ALTERATION. AS THE EVAS IS SELF-CONTAINED, NO ADDITIONAL INSTALLATION IS NEEDED.

2. THE INDICATED LOCATION IS A SUGGESTION. AS EVAS IS LOOSE EQUIPMENT, IT MAY BE STORED IN ANOTHER CONVENIENT LOCATION ACCESSIBLE TO THE PILOT. HOWEVER, PRIOR TO DEPLOYING EVAS, THE UNIT MUST BE ON THE OUTBOARD SIDE OF THE PILOT AND WITHIN ARMS REACH OF THE GLARE SHIELD.

VELCRD

1. CLEAN THE GLARE SHIELD TOP SURFACE FROM THE AFT EDGE FORWARD 5', AND 3' TO EACH SIDE OF THE LONGITUDINAL CENTERLINE THROUGH THE CONTROL WHEEL.
2. CEMENT 1'x5" LOOP VELCRD TO THE GLARE SHIELD. LOCATE THE VELCRD AS SHOWN ON SHEET 4 OF 4. USE DEVCON TWO-TON EPOXY CEMENT.

DOCUMENTATION

1. IN THE OPERATING MANUAL, FLIGHT MANUAL, OR CHECK LIST, AS APPROPRIATE, ADD "DEPLOY EVAS" TO EACH SMOKE EMERGENCY PROCEDURE. USE PERMANENT METHODS COMMENSURATE WITH THE ORIGINAL DOCUMENT, SUCH AS TYPEWRITTEN, PLASTIC-COATED LABEL, ETC.

| | | | | | |
|-------|----------|----------|-------|------|------|
| SIZE | FSCM NO. | DRG NO. | 6080 | REV. | - |
| B | | | | | |
| SCALE | LOCATION | 6080003- | SHEET | 3 | of 4 |

2

1

A

B

A

B

- NOTE:
1. CLEAN SURFACE
 2. USE DEVCON TWO TON EPOXY

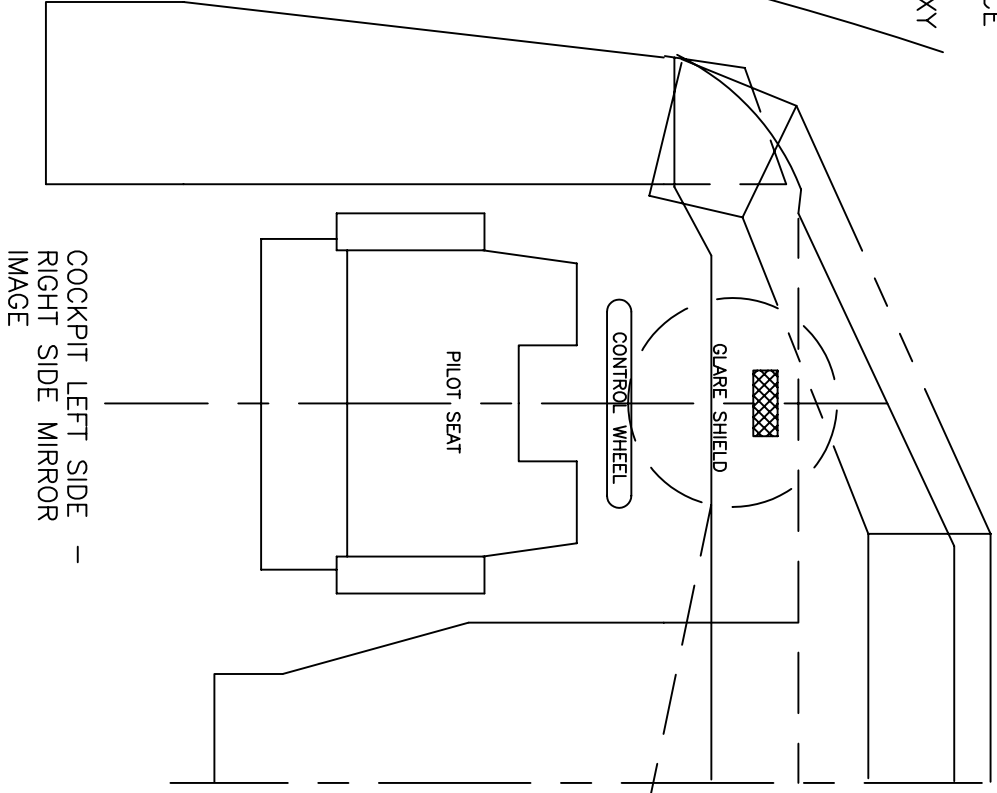

COCKPIT LEFT SIDE -
RIGHT SIDE MIRROR
IMAGE

THE INFORMATION CONTAINED HEREIN IS PROPRIETARY AND CONFIDENTIAL TO VISION SAFE CORP., AND SHALL NOT BE DISCLOSED OR COPIED, IN WHOLE OR IN PART WITHOUT THE WRITTEN CONSENT OF VISION SAFE CORP.

IVU VELCRO INSTALLATION

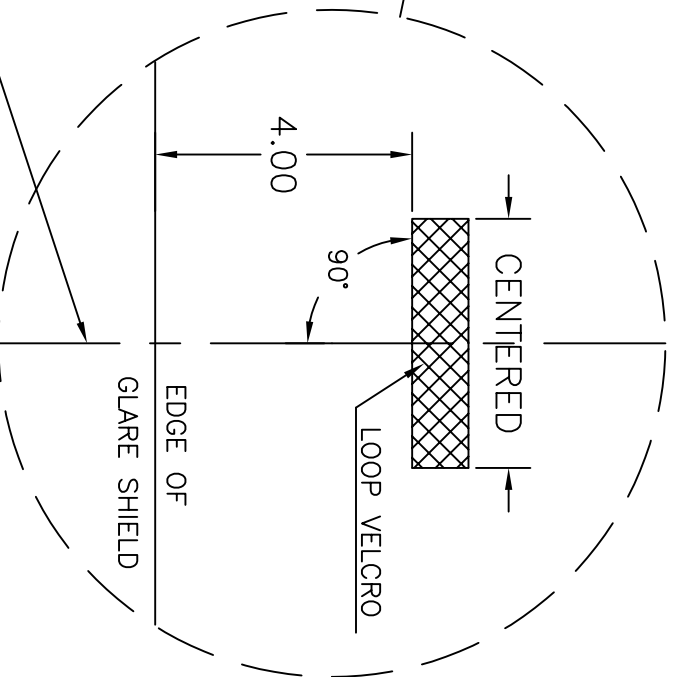

NOTE: GLARE SHIELD EDGE ANGLE IS NOT AIRCRAFT SPECIFIC. VELCRO CENTER SHOULD BE AS INDICATED.

CENTERLINE OF PILOT SEAT, CONTROL WHEEL AND PRIMARY FLIGHT INSTRUMENTS.